

7	8	9	10	11
REV	DESCRIPTION	APPROVAL	DATE	
A	Initial Release		00.07.21	

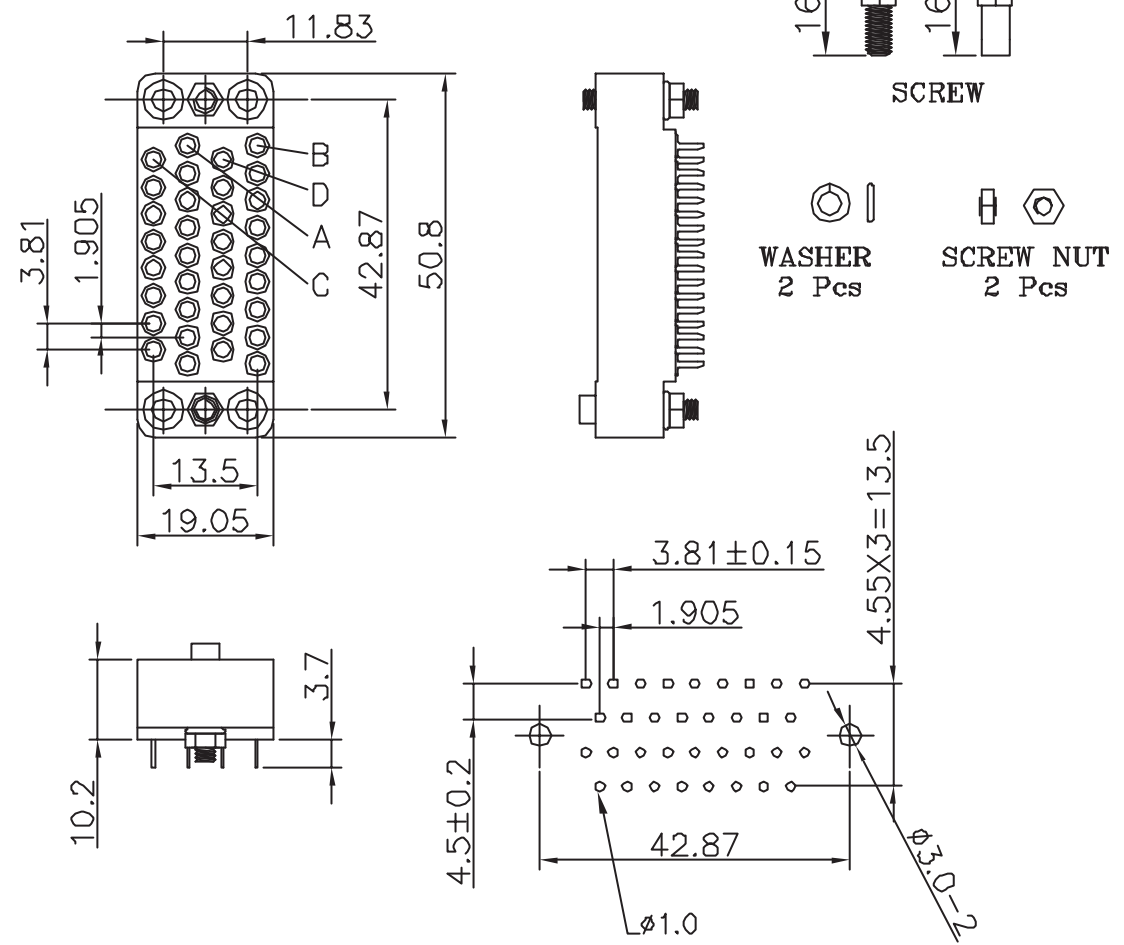

MECHANICAL

INSULATOR MATERIAL:
PBT & Glass-fibre reinforced
UL-94-V0

CONTACT:
Phosphor bronze

ELECTRICAL

CURRENT RATING:
7 Amp

WITHSTANDING VOLTAGE:
AC 1200V Min. (for one minute)

INSULATION RESISTANCE:
1000MΩ Min.(at 500V DC)

CONTACT RESISTANCE:
10mΩ Max. mated

WORKING TEMPERATURE:
-55° C to +105° C

MATING CYCLE
300 Times Min

PANSTRONG COMPANY LTD.				DRAWN BY		TOMMY	
				CHECKED			
TITLE:		V.35 PCB STRAIGHT FEMALE				APPROVED	
PART NO:		V35F0102K				DRAW NO	
File Number:							
SCALE	FREE	REV	A	UNIT	mm		

SELECT DIM	1	2	3	EXTRA
0.000	0.05	0.05	0.10	
0.00	0.10	0.15	0.20	✓
0.0	0.15	0.25	0.30	✓
0.	0.25	0.30	0.40	✓
ANGLE	1.0°	3.0°	5.0°	✓