

REMARK: RoHS COMPLIANT

| REV | DESCRIPTION     | DATE      |
|-----|-----------------|-----------|
| A   | Initial Release | 06'.08.02 |

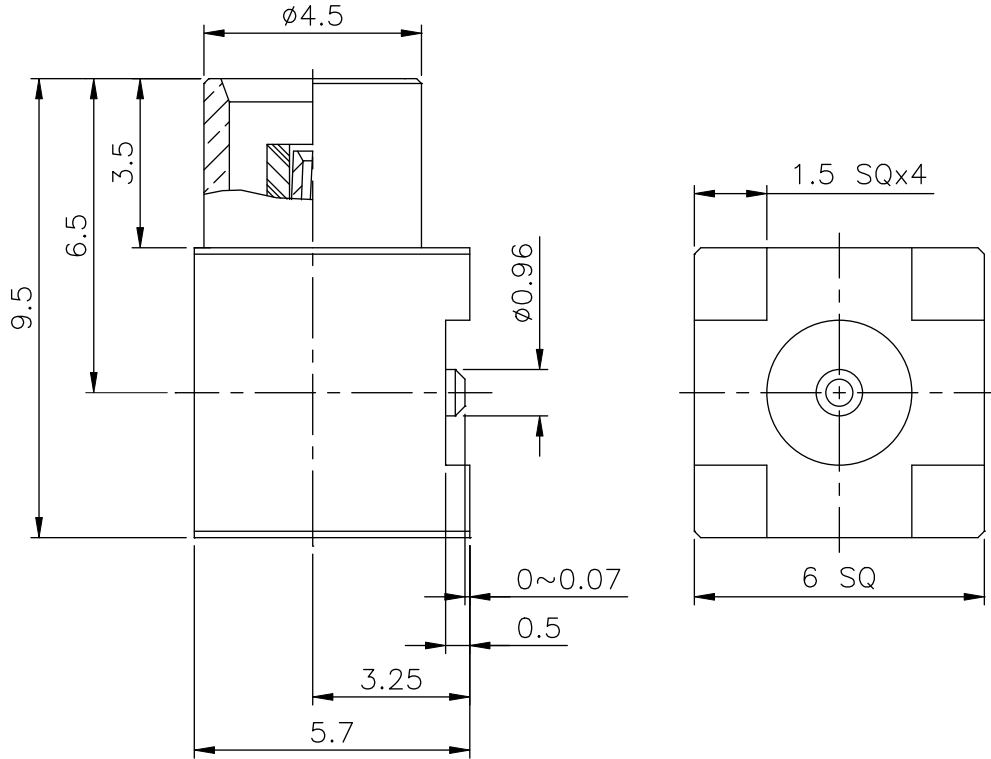

- FINISH (PLATING THICKNESS IN MICRO-INCHES)
1. BRASS PER QQ-B-626
  2. GOLD PL 3 MIN OVER NICKEL PL 70 MIN THICK OVER COPPER STRIKE
  3. GOLD PL 30 MIN OVER NICKEL PL 70 MIN THICK OVER COPPER STRIKE
  4. TEFLON MIL-P-19468
  5. BERYLLIUM COPPER PER QQ-C-530

| NO. | DESCRIPTION | MATERIAL | FINISH |
|-----|-------------|----------|--------|
|     | INSULATOR   | NOTE 4   | WHITE  |
|     | BODY        | NOTE 1   | NOTE 2 |
|     | INSULATOR   | NOTE 4   | WHITE  |
|     | CONTACT PIN | NOTE 5   | NOTE 3 |
|     | CUBE BODY   | NOTE 1   | NOTE 2 |

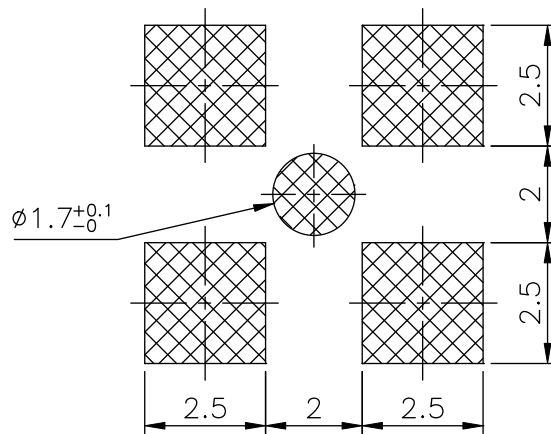

RECOMMENDED  
SOLDERING PADS

DIMENSIONS ARE IN MILLIMETERS  
UNLESS OTHERWISE SPECIFIED  
TOLERANCES

|           |        |
|-----------|--------|
| 0.5~6     | = ±0.2 |
| >6~30     | = ±0.4 |
| >30~120   | = ±0.6 |
| >120~315  | = ±1   |
| >315~1000 | = ±1.6 |
| ANGLES    | = ±5°  |

| PANSTRONG COMPANY LTD. |     |                  |   | DRAWN BY | TOMMY |
|------------------------|-----|------------------|---|----------|-------|
| TITLE:                 |     | MCX R/A SMT JACK |   | CHECKED  |       |
| PART NO:               |     | XF02G0103        |   | APPROVED |       |
| File Number:           |     |                  |   | DRAW NO  |       |
| SCALE                  | 6:1 | REV              | A | UNIT     | mm    |

