

REV	DESCRIPTION	APPROVAL	DATE
A	Initial Release		07'.09.21

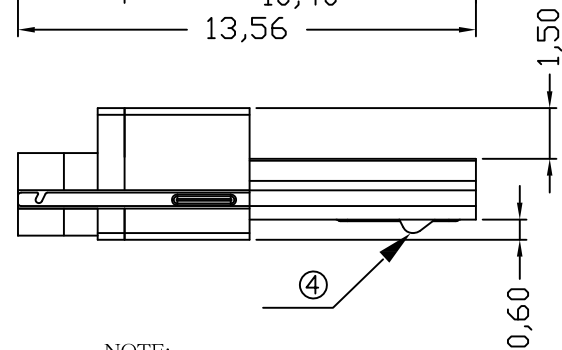
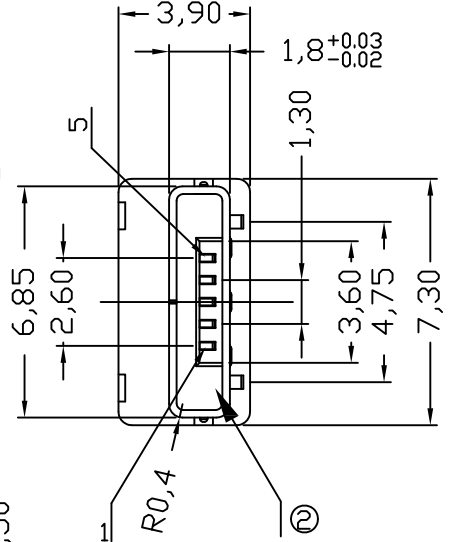
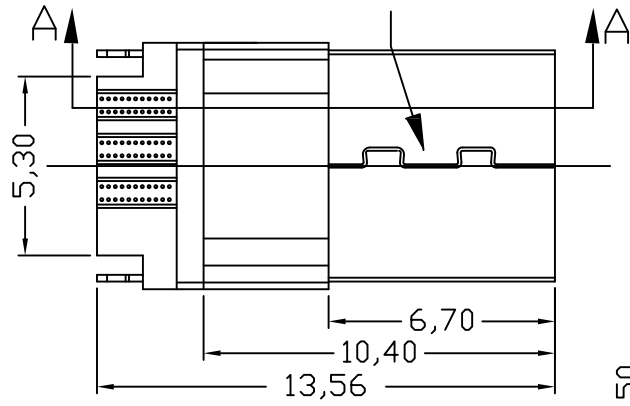
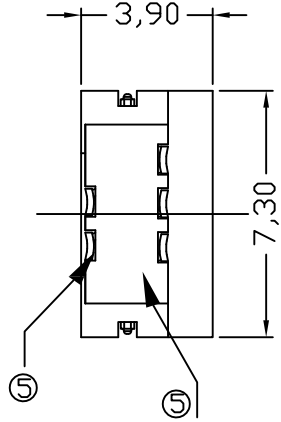
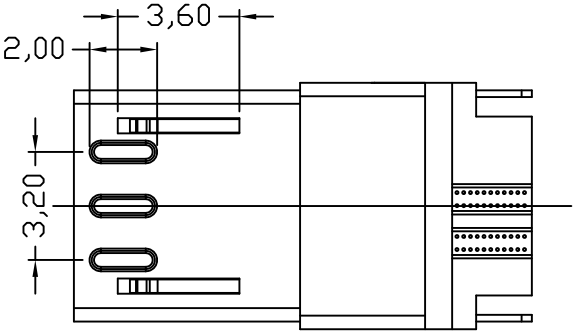
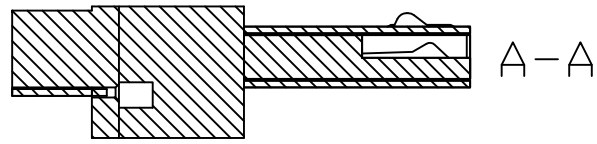
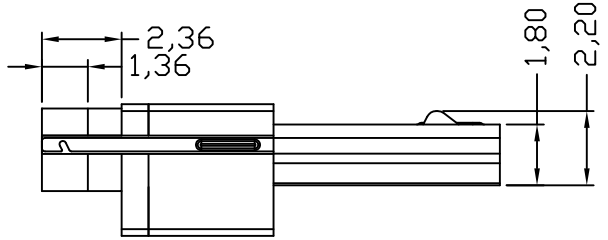

PART NO.

MMUA13 - 5 M W 30
 1 2 3 4 5

- 1.MMUA13:Micro USB A Type, Wire Solder for Molding
- 2.No. of Contact: 5:5 Positions
- 3.M: Plug
- 4.Insulator Color: W:White K: Black
- 5.Contact Gold Plating: 30:30u" Gold

NOTE:
 1.PIN4 IS NOT CONNECTED TO PIN 5 INSIDE THE PLUG.
 2.DIMENSIONS THAT ARE LABELED REF MAY VARY FROM MANUFACTURER TO MANUFACTURER.
 3.GENERAL TOLONCE IS +/-0.05mm,OTHERWISE THE SPECIFIED TOLERANCES APPLY.

NO.	PART NAME	MATERIALS	THICKNESS	Q'TY	REMARK
5	BLACK LOCK	LCP		1	B0001
4	LATCH	STEEL	0.40mm	1	B0001
3	SHELL	STAINLESS	0.20mm	1	B0001
2	HOUSING	LCP		1	B0001
1	CONTACT	C5191	0.20mm	5	B0001

一般公差
 .x ±0.25
 .xx ±0.10

貝強實業有限公司 PANSTRONG COMPANY LTD.				DRAWN BY		TOMMY	
				CHECKED			
TITLE:		MICRO USB A (M) MOLDING TYPE		APPROVED			
PART NO:		MMUA13-5MW30		DRAW NO			
File Number:				UNIT		mm	
SCALE	1:1	REV	A	UNIT		mm	

