

REV	DESCRIPTION	DATE
A	Initial Release	07.03.09

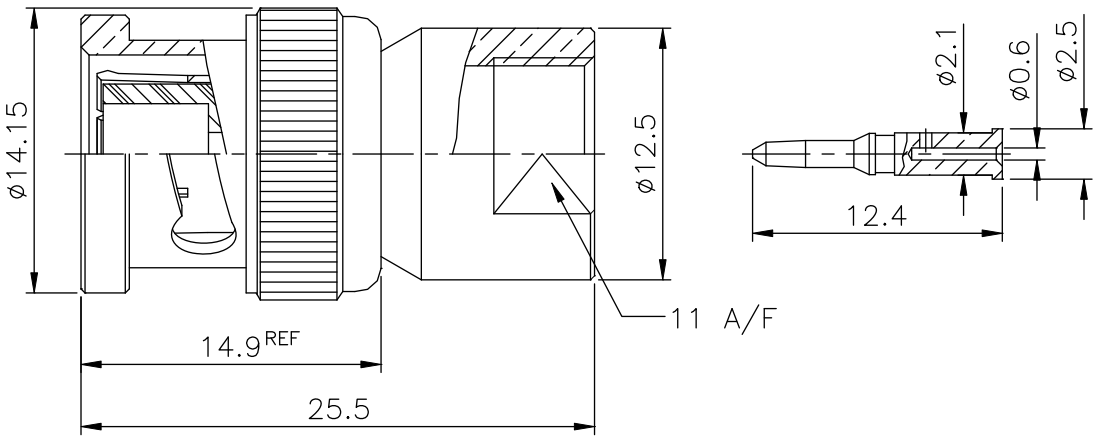

FINISH (PLATING THICKNESS IN MICRO-INCHES)
 1. BRASS PER QQ-B-626
 2. NICKEL PL 70 MIN THICK OVER COPPER STRIKE
 3. GOLD PL 3 MIN OVER NICKEL PL 70 MIN THICK OVER COPPER STRIKE

NUT	NOTE 1	NOTE 2
WASHER	NOTE 1	NOTE 2
GASKET	SILICONE	ORANGE
BRAID HOLDER	NOTE 1	NOTE 2
CONTACT PIN	NOTE 1	NOTE 3
SHELL	NOTE 1	NOTE 2
GASKET	RUBBER	RED
C RING	SS41	NOTE 2
SPRING	SK5	NOTE 2
WASHER	SS41	NOTE 2
INSULATOR	DELTRIN	WHITE
BODY	NOTE 1	NOTE 2
DESCRIPTION	MATERIAL	FINISH

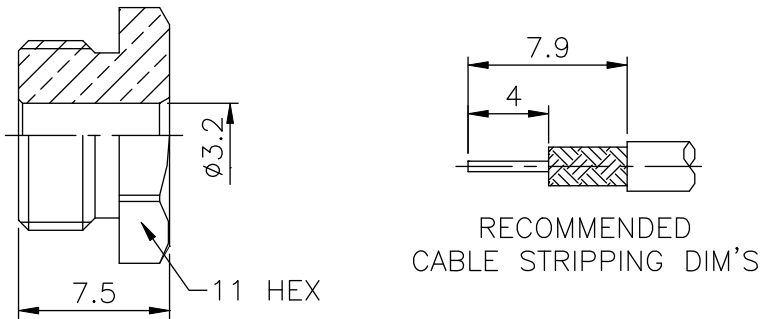
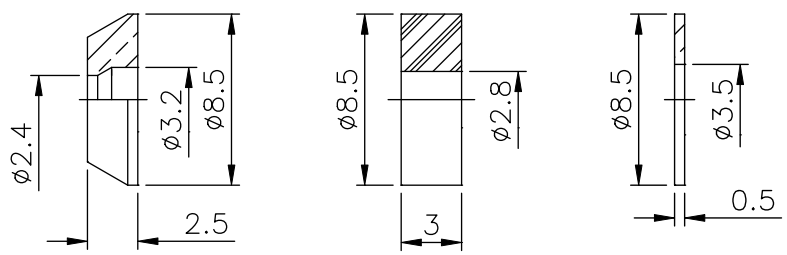

1. CRIMPED CONTACT PIN
 HEX CRIMP SIZE .068" (1.72mm)

RoHS COMPLIANT

UNLESS OTHERWISE SPECIFIED TOLERANCES

0.5-4	= ±0.2
>4-30	= ±0.4
>30-120	= ±0.6
>120-315	= ±1
>315-1000	= ±1.6
ANGLES	= ±5°

PANSTRONG COMPANY LTD.				DRAWN BY		TOMMY	
				CHECKED			
TITLE:		BNC CLAMP PLUG (FOR RG-174/U,188A/U,316/U)				APPROVED	
PART NO:		BM02N0212-3				DRAWING NO.	
SCALE		2.5:1	REV	A	UNIT	mm	