

REV	DESCRIPTION	DATE
A	Initial Release	06:11.03
B	Ordering Code Change	07:09.26

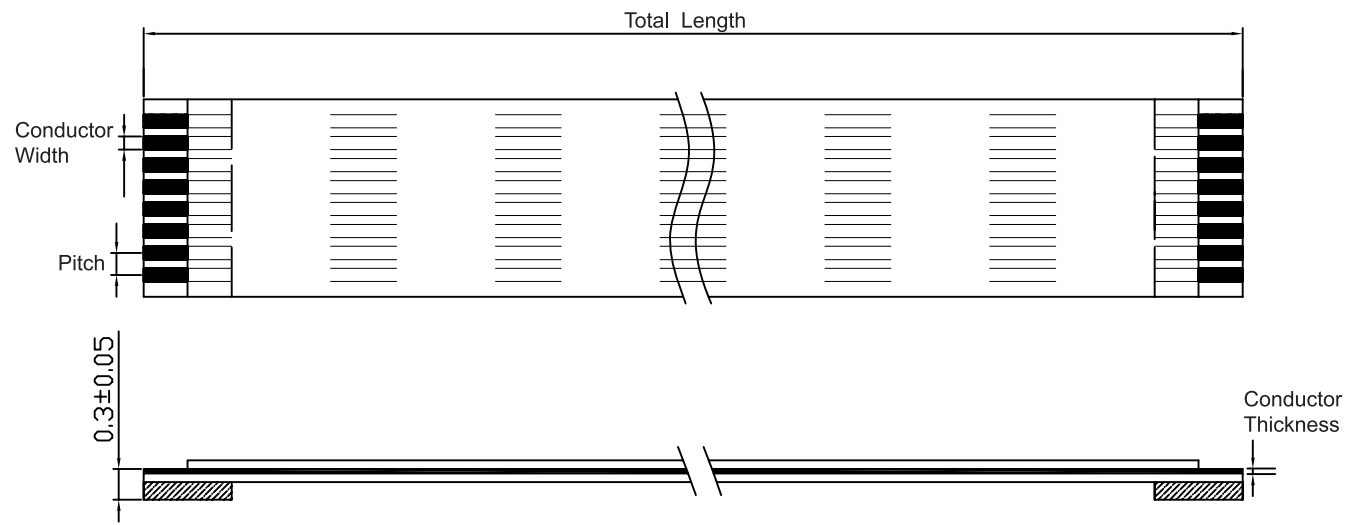
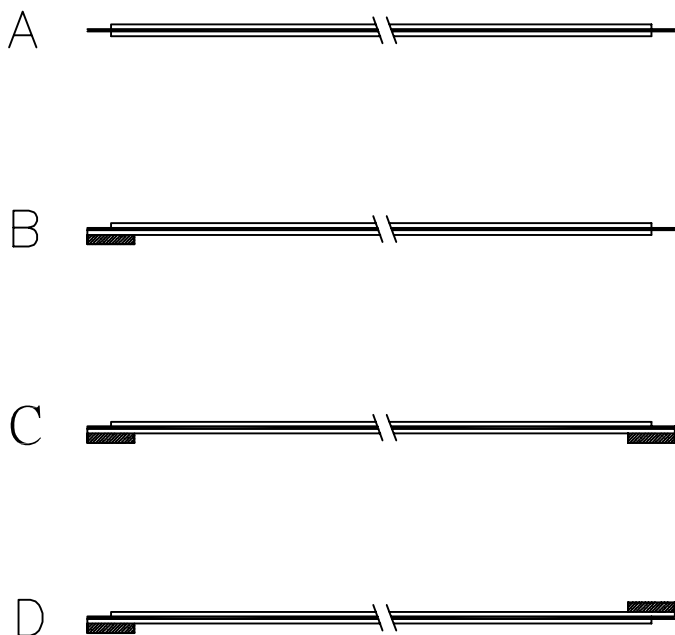

How to Order:

FFC - xx - E - xxx - X - X X X
 1 2 3 4 5 6 7

- Number of Contact Pins
- Pitch Type: 0.5mm
- Total length(in mm)
- Cable End Type
A,B,C,D
- Cable End Strip and Support Plate Length
(Type A without Support Plate)
 1. 3/3/5/5 2. 4/4/10/10 3. 4/4/8/8
 4. 5/5/10/10 5. 4/4/6/6 6. 2/2/3/3
- Conductor Thickness
 1 : 0.035mm 2 : 0.05mm
- Conductor Width
 1 : 0.3mm

N O 編號	Specifcation 規格部位名稱	Select size 選擇訂購尺寸
P	導體間距 Conductor pitch	
N	導體數目 Conductor number	
L	總長度 Total Length	
T	樣式 Type	C
S 1	剝皮長度 Strip Length	4 ±1
S 2	剝皮長度 Strip Length	4 ±1
d 1	加強長度 Support Length	7 ±1.5
d 2	加強長度 Support Length	7 ±1.5

Abbr.圖示編號 Specification Formulation	Tolerance 參考公差 (mm)				
	0.5	0.8	1.0	1.25	2.54
P 導體間距 Conductor Pitch	±0.05	±0.08	±0.08	±0.1	±0.2
P t 總間距 (n-1) P Total conductor Pitch	±0.08	±0.1	±0.1	±0.15	±0.2
W 總寬度 Total width (n+1)P	±0.08	±0.1	±0.1	±0.2	±0.2
L 總長度 Total Length	30-200±3, 401-1000±12.		201-400±6.		
C w 導體寬度 Conductor width	0.30	0.5	0.6	0.8	1.27
	±0.02				

Rated Voltage AC 500V max
 Contact resistance : Max 50mΩ
 Isolation Thickness 0.1+/-0.05mm
 Cable : UL Type, 80°C, 60V

	DRAWN BY	TOMMY
	CHECKED	
TITLE:	FFC CABLE	
PART NO:	FFC-xx-E-xxx-X-XXX	
SCALE	/	REV A
	UNIT	mm
	APPROVED	
	DRAWING NO.	