

REV	DESCRIPTION	DATE
A	Initial Release	10'.05.04
D	Chang Terminal Under-Plating	11'.01.18
E	Explicit Plastic Material	11'.04.18

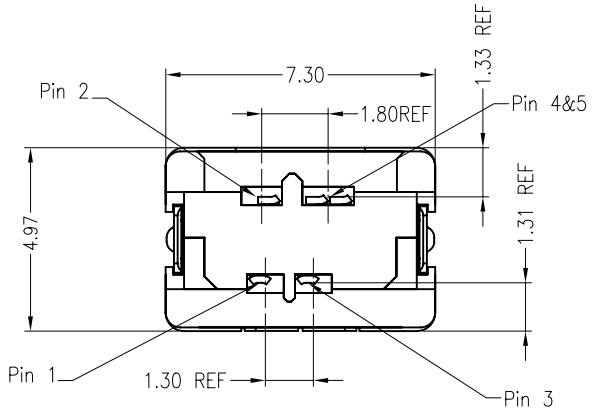
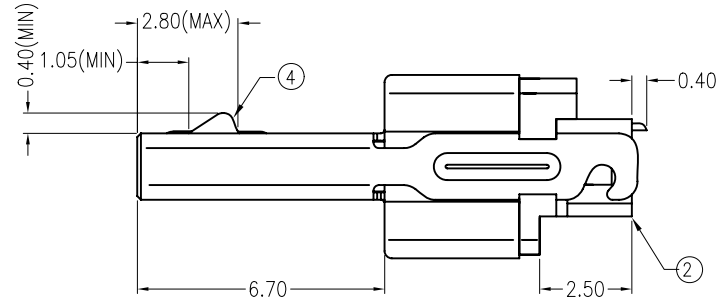
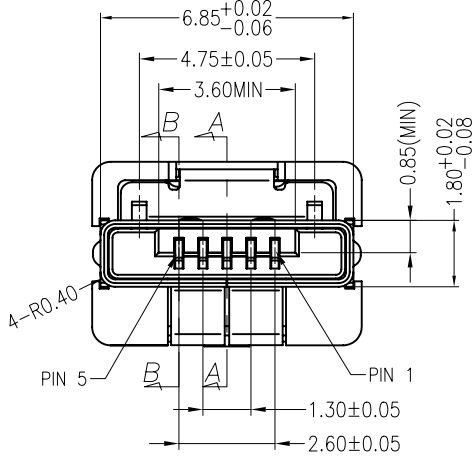
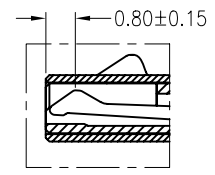
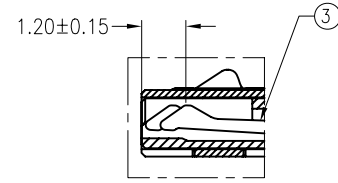
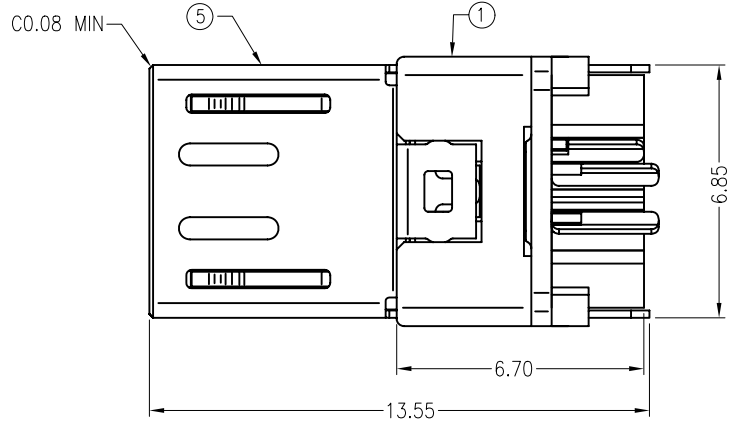
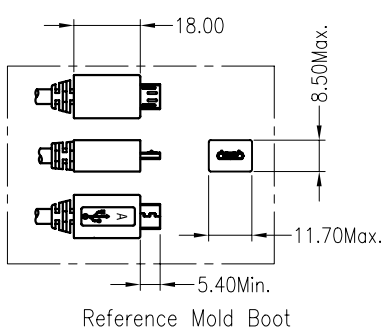

NOTE:

NEW PART NO.	CONTACT AREA PLATING	FRONT SHELL PLATING	UNDER-PLATING
▲ MMUA13-5MW30	Au 30u"	Ni 20u"	Ni 80u" ▲

NOTE 1 : " ▲ " IS STANDARD PRODUCT

ITEM	DESC.	MATERIAL	REMARKS
5	FRONT SHELL	STAINLESS STEEL, T=0.20	Ni 20u" PLATED
4	LATCH	STAINLESS STEEL, T=0.40	
3	CONTACT	COPPER ALLOY,T=0.20	CONTACT AREA: Au 30u" SOLDER AREA: Sn 50u" UNDER-PLATING:Ni 80u"
2	COVER	LCP ▲	COLOR:BLACK
1	HOUSING	LCP ▲	COLOR:NATURE

TOLERANCES
DIM. ±0.30
ANGLE: ±3°

PANSTRONG COMPANY LTD.				DRAWN BY		TOMMY	
				CHECKED			
TITLE:		MICRO USB-A PLUG COMBING TYPE Halogen-Free				APPROVED	
PART NO:		MMUA13-5MW30				DRAW NO	
File Number:							
SCALE	5:1	REV	E	UNIT	mm		